

LegSim Measurement Form

To be filled out by patient, prosthetist, and/or physical therapist.

Name _____ Date _____

Phone _____ Fax _____

E-mail _____

Address _____

City _____ State _____ Zip Code _____

Age _____ Sex _____ Weight _____ (lbs.) Waist _____" Hips _____" Height _____" Shoe size _____

Type of Injury _____ BK _____ AK _____ Missing or Injured Leg: L _____ R _____ Bilateral _____

Missing or Injured Hand: L _____ R _____

Crotch to floor with shoe on _____ (inches) Inseam _____ (inches)

Able to stand on one leg: Yes _____ No _____ Able to balance on one leg: Yes _____ No _____

Prosthetist _____ Company _____

Phone _____ Fax _____

Address _____

City _____ State _____ Zip Code _____

..... AREA BELOW FOR OFFICE USE ONLY

Max. Length _____ Min. Length _____ Max Weight _____

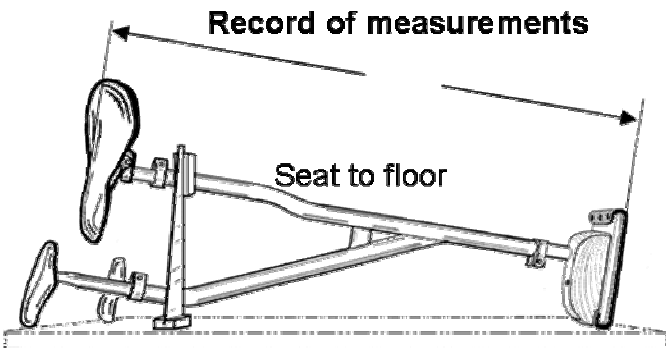

Front view of handlebar

Short Side is missing side.

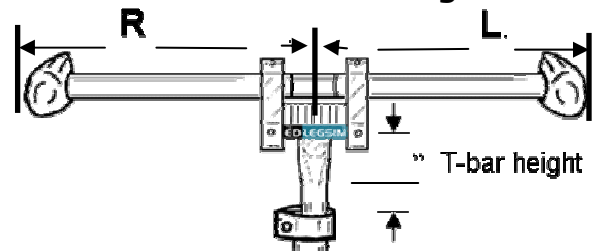

Barcode # _____

Seat to floor _____
 JH, SU, DP Stabilizer L _____ R _____
 Stabilizer offset _____
 Foot Type _____ Max Weight _____ Post Length _____
 Foot Post Type _____ Foot Tread Type _____
 T-bar size _____ x _____ Type _____
 Handlebar OD size _____ Type _____
 Handlebar offset L _____ R _____ Missing Side _____
 Seat Type _____
 Seat Clamp in. lb. _____
 Seat clamp behind post _____
 Seat clamp forward post _____
 Frame Type _____ Max Weight _____ (lbs.)
 Frame size _____" x spread _____"
 Frame clamps in. lb. _____ Type _____

